

cimPRESS XLC Inline Check Valve

cim30XLC.1

CimPRESS x CimPRESS

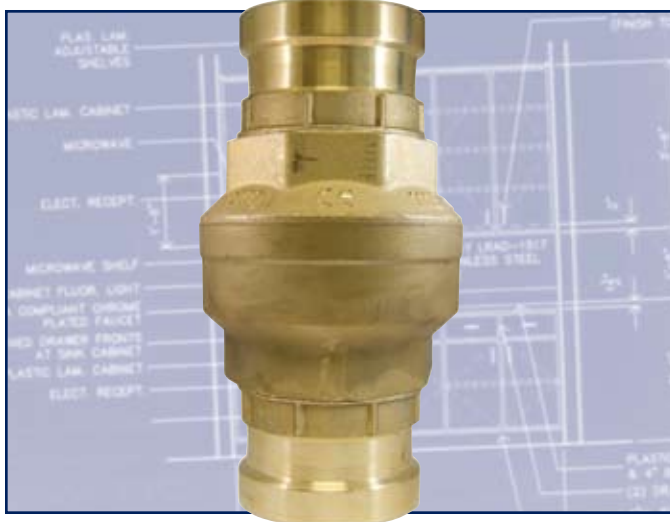

Applications:

The CIM 30XLC.1 CimPRESS inline check valve is manufactured in accordance with MSS-SP-110, PS117-2004, and EN ISO 9001 standards and designed for direct connection to hard drawn copper and/or stainless steel tube using standard press tools with XL-C jaws and rings. The CIM 30XLC.1 is suitable for use with non-aggressive fluid applications including domestic and commercial plumbing and sanitary systems as well as autoclaves, pumps and compressed air systems. (CimPRESS is not intended for use with soft or rolled copper tubing)

Features:

The CIM 30XLC.1 inline check valve utilizes a compact noiseless design that provides a low pressure drop and reduced water-hammer. The CIM 30XLC.1 is built with a double stem guide to facilitate trouble free operation and a stainless steel spring-loaded Hostaform thermoplastic free rotating stem that opens at .36 PSI. The CIM 30XLC.1 will provide a full flow area equal to the nominal size, and can be installed vertically, horizontally or at an angle in a pipeline to accommodate flow in one direction.

CimPRESS valves were developed as purpose built valves for standard press attachment to eliminate the need to assemble separate components in the field, which could result in weak/leak points and increased material and labor costs. The CIM 30XLC.1 is manufactured from DZR "CR" corrosion-resistant brass with EPDM-ASTM D 2000 M2 O-Rings to ensure a leak proof cold crimped seal with added protection against corrosion.

CimPRESS valves eliminate the torch and the need to clean, flux and solder in order to create a permanent watertight valve connection, significantly reducing average installation time while avoiding potential fire risks and other problems associated with sweat connections; saving time and money.

Connection:

Standard press connection for copper and stainless steel tube plumbing systems. **For use with XL-C press jaws and rings only.**

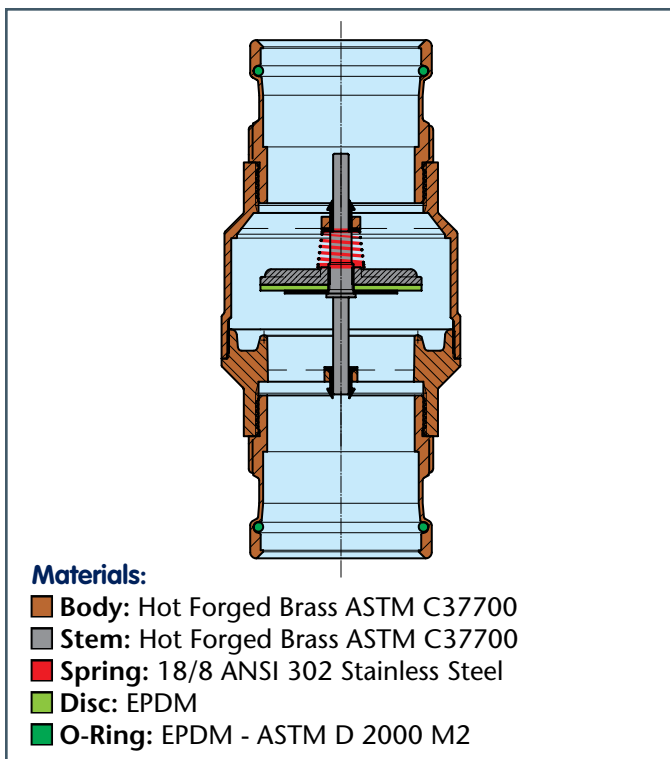

All Cimberio valves qualify for the American Recovery and Reinvestment Act and the Buy American Act.

Size	Fast Order No.	Technical ID No.
2-1/2"	30XLC-11	CIM30XLC-E11ICV
3"	30XLC-12	CIM30XLC-E12ICV
4"	30XLC-14	CIM30XLC-E14ICV

cimPRESS XLC Inline Check Valve

cim30XLC.1

CimPRESS x CimPRESS

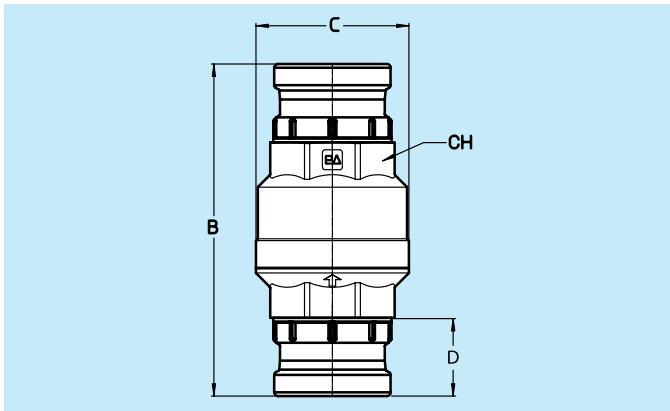

Size	2-1/2"	3"	4"
B	10-1/16" 255mm	10-1/2" 267mm	10-15/16" 278mm
C	4-1/16" 103mm	4-7/8" 123mm	6-5/16" 160mm
D	2-3/16" 55mm	2-3/16" 55mm	2-3/8" 60mm
CH	3-7/16" 88mm	3-15/16" 100mm	4-7/8" 123mm
Pounds	8.34	11.34	16.9
Grams	3785	5142	7668
Required Pipe Insertion Depth	2.1685" 55.08mm	2.1525" 54.67mm	2.3565" 59.85mm

FLOW AND PRESSURE DROP

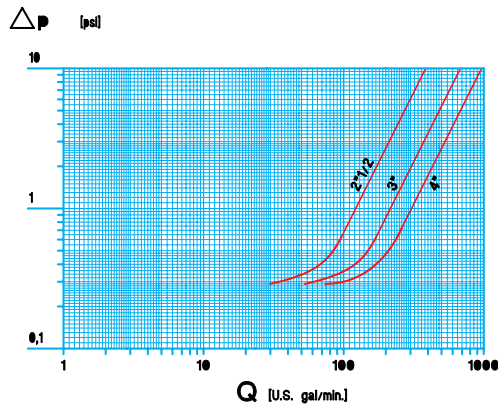

PRESSURE/TEMPERATURE RATINGS

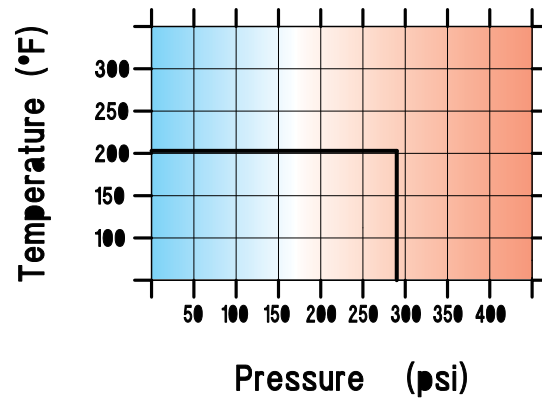

CV

CV: Capacity in "U.S. gal/min" at pressure drop of "1 PSI"

Element: Water - Temperature: 59.9° F

30XLC.1 SIZE	2-1/2"	3"	4"
CV	124.9	222.1	305.4

Working Pressure: 290 PSI

Max. Operating Temperature: Working Limit for Fluids 14° F – 212° F

Test Pressures: According to ISO 5208